

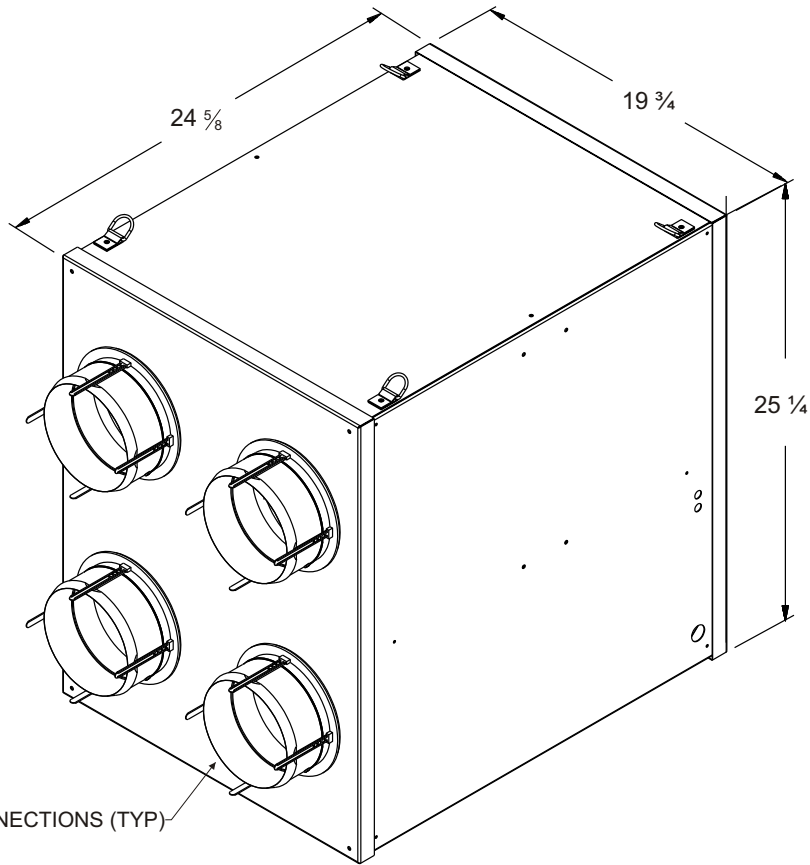

**SPECIFICATION DATA FOR
RESIDENTIAL AIR VENTILATION EQUIPMENT
"RAVE"
RSI MODEL# 01-R02-01**

Features

1. Cabinet Finish: G-90 embossed galvanized steel or powder painted as required.



6" ROUND DUCT CONNECTIONS (TYP)



Energy recovery COMPONENT certified to the AHRI Air-to-Air Energy Recovery Ventilation Equipment Certification Program in accordance with ARI Standard 1060-2000 . Actual performance in packaged equipment may vary.



ETL Certified per UL 1812 and CAN/CSE C349.00

Ventilation Capacity	CFM @ 0.0 (Max)	250
	CFM @ 0.6 (Min)	50
Sensible Efficiency	CFM @ 200	72
	CFM @ 150	74
Latent Efficiency	CFM @ 200	68
	CFM @ 150	71
Total Efficiency (Enthalpy)	CFM @ 200	70
	CFM @ 150	72
Electrical Ratings	@ 6 AMPS	120 VAC
Dimensions	Height	25.125
	Width	19.750
	Length	24.500
Weight	Shipping (lbs)	100
	Net (lbs)	90

FOR LIST PRICES:

SEPTEMBER 15, 2009 FORM# RSKRERV01

SUPERSEDES 05-27-09



2405 McIver Lane, Carrollton, Texas 75006-6510 Phone (972) 247-7447 (800) 552-4822 Fax (972) 243-0940