

**2005
GUIDELINE for**

**SELECTING,
SIZING, &
SPECIFYING
PACKAGED AIR-
TO-AIR ENERGY
RECOVERY
VENTILATION
EQUIPMENT**



Guideline W

IMPORTANT

SAFETY DISCLAIMER

ARI does not set safety standards and does not certify or guarantee the safety of any products, components or systems designed, tested, rated, installed or operated in accordance with this standard/guideline. It is strongly recommended that products be designed, constructed, assembled, installed and operated in accordance with nationally recognized safety standards and code requirements appropriate for products covered by this standard/guideline.

ARI uses its best efforts to develop standards/guidelines employing state-of-the-art and accepted industry practices. ARI does not certify or guarantee that any tests conducted under its standards/guidelines will be non-hazardous or free from risk.

Note:

This is a new guideline.

TABLE OF CONTENTS

SECTION	PAGE
Section 1. Purpose.....	1
Section 2. Scope.....	1
Section 3. Definitions	1
Section 4. Air-to-Air Energy Recovery Ventilation Equipment (AAERVE) Classifications	3
Section 5. Frost and Condensation	4
Section 6. System Balancing	5
Section 7. Economizer Operation	6
Section 8. Design Considerations and Air-Conditioning Equipment Selection	6
Section 9. AAERVE Sizing.....	8
Section 10. Specification Practices for AAERVE.....	8

TABLE

Table 1. Classes of Air and Energy Recovery Ventilation Applications.....	7
---	---

APPENDICES

Appendix A. References - Normative	10
Appendix B. References - Informative.....	10
Appendix C. Example Specification for Stand Alone System, Rooftop or Indoor - Informative.....	11
Appendix D. Example Specification for Stand Alone - Coupled System, Rooftop or Indoor – Informative.....	12
Appendix E. Example Specification for Unitized System, Rooftop or Indoor – Informative.....	13
Appendix F. Example Specification for Integrated Energy Recovery System, Rooftop or Indoor - Informative	14

FIGURES FOR APPENDICES

Figure C1. Typical Stand Alone System - Rooftop11

Figure D1. Typical Stand Alone-Coupled System (one of many possibilities).....12

Figure E1. Unitized System13

Figure F1. Integrated System14

SELECTING, SIZING, & SPECIFYING PACKAGED AIR-TO-AIR ENERGY RECOVERY VENTILATION EQUIPMENT

Section 1. Purpose

1.1 Purpose. The purpose of this guideline is to provide information to support the application of Air-to-Air Energy Recovery Ventilation Equipment (AAERVE). This guideline supports AAERVE that is manufactured using Air-to-Air Heat Exchangers (energy recovery components) rated in accordance with ARI Standard 1060. These energy recovery components include Heat Pipe Heat Exchangers, Plate Heat Exchangers, and Rotary Heat Exchangers.

1.1.1 Intent. This guideline is intended for the guidance of the industry, including architects, engineers, contractors, manufacturers, and end users.

1.1.2 Review and Amendment. This guideline is subject to review and amendment as technology advances.

Section 2. Scope

2.1 Scope. This guideline applies only to AAERVE.

2.2 Applications. This guideline is intended to apply primarily to commercial and institutional applications.

2.3 Exclusions. This guideline does not apply to heat exchangers joined by circulated heat transfer medium (run-around loop). A run-around loop employs liquid-containing coils connected in a closed loop and placed in each of two or more airstreams.

Section 3. Definitions

All terms in this document follow the standard industry definitions in the current edition of *ASHRAE Terminology of Heating, Ventilation, Air Conditioning and Refrigeration* and ASHRAE Standard 84, unless otherwise defined in this section.

3.1 Air-to-Air Energy Recovery Ventilation Equipment (AAERVE). Energy recovery components and packaged energy recovery ventilation units which employ Air-to-Air Heat Exchangers to recover energy from exhaust air for the purpose of pre-conditioning outdoor air prior to supplying the conditioned air to the space, either directly or as part of an air-conditioning (to include air heating, air cooling, air circulating, air cleaning, humidifying and dehumidifying) system.

3.2 Air-to-Air Heat Exchanger. A device that transfers heat from an exhaust airstream to a separated supply airstream. Air-to-Air Heat Exchangers are also referred to as energy recovery components.

3.2.1 Heat Pipe Heat Exchanger. A device employing tubes charged with a fluid for the purpose of transferring sensible energy from one airstream to another. Heat transfer takes place through the vaporization of the fluid exposed to the warmer airstream and condensation of the fluid in the cooler airstream.

3.2.2 Plate Heat Exchanger. A device for the purpose of transferring energy (sensible or total) from one airstream to another with no moving parts. This exchanger may incorporate parallel, cross or counter flow construction or a combination of these to achieve the energy transfer.

3.2.3 Rotary Heat Exchanger. A device incorporating a rotating cylinder or wheel for the purpose of transferring energy (sensible or total) from one airstream to the other. It incorporates heat transfer material, a drive mechanism, a casing or frame, and includes any seals, which are provided to retard the bypassing and leakage of air from one airstream to the other.

3.3 Economizer. A system of controls and dampers that introduces outside air to a space when the space requires cooling, and the temperature and/or enthalpy of the outside air is lower than the temperature and/or enthalpy of the space.

3.3.1 *Sensible Only.* A system that utilizes an outdoor air sensor that measures outdoor dry-bulb temperature only. If the space has a cooling requirement, outside air will be used if the outdoor dry-bulb temperature is less than or equal to the control setpoint.

3.3.2 *Enthalpy.* A system that utilizes an outdoor sensor that measures the total heat (both the sensible and latent) of the outside air. If the space has a cooling requirement, outside air will be used to cool the space if the total heat of the outside air is less than or equal to the control setpoint.

3.4 *Effectiveness.* The measured energy recovery not adjusted to account for that portion of the psychrometric change in the Leaving Supply Airflow that is the result of leakage of Entering Exhaust Airflow rather than exchange of heat or moisture between the airstreams.

3.5 *Entering Air Conditions.* The dry-bulb and wet-bulb temperature that is entering the space on a stand alone system, or entering the air-conditioning system on integrated, stand alone-coupled or unitized systems. These conditions typically replace the “outdoor air conditions” in most design load software programs. These are also referred to as the Tempered Outside Air conditions. On stand alone systems these are also referred to as Supply Airflow conditions.

3.6 *Exhaust Airflow.* Airflow leaving the conditioned space.

3.6.1 *Entering Exhaust Airflow (Return Air).* The exhaust airstream before passing through the heat exchanger, shown as Station 3 in ASHRAE Standard 84.

3.6.2 *Leaving Exhaust Airflow (Exhaust Air to Outside).* The exhaust airstream after passing through the heat exchanger, shown as Station 4 in ASHRAE Standard 84.

3.7 *Exhaust Air Transfer Ratio (EATR).* The tracer gas concentration difference between the Leaving Supply Airflow and the Entering Supply Airflow divided by the tracer gas concentration difference between the Entering Exhaust Airflow and the Entering Supply Airflow at the 100% Rated Airflows, expressed as a percentage.

3.8 *Net Building Load.* The total calculated space conditioning energy required for a building including the impact of energy recovery. This is the total building load minus the total energy recovered from the exhaust air. The Net Building Load may be calculated for both heating and cooling design conditions.

3.8.1 *Example.* Total building cooling load is 200 tons including outside air without the AAERVE. The AAERVE reduced the outdoor air load by 75 tons. The Net Building Load is 125 tons (200 tons -75 tons).

3.9 *Net Effectiveness.* The measured energy recovery Effectiveness adjusted to account for that portion of the psychrometric change in the Leaving Supply Airflow that is the result of leakage of Entering Exhaust Airflow rather than exchange of heat or moisture between the airstreams.

3.10 *Net Zone Load.* The total space conditioning energy required for a particular zone of a building including the impact of energy recovery. This is the Total Zone Load minus the total energy recovered from the exhaust air for the Zone by the AAERVE. The Total Zone Load may be calculated for both cooling and heating design conditions.

3.10.1 *Example.* Total zone cooling load is 20 tons including outside air without the AAERVE. The AAERVE reduced the outdoor air load by 7.5 tons. The Net Zone Load is 12.5 tons (20 tons -7.5 tons).

3.11 *Outdoor Air Correction Factor (OACF).* The Entering Supply Airflow divided by the measured (gross) Leaving Supply Airflow.

3.12 *Published Rating.* A statement of the assigned values of those performance characteristics at stated Rating Conditions, by which a unit may be chosen for its application. These values apply to all AAERVE of like size and

type (identification) produced by the same manufacturer. The term Published Rating includes the rating of all performance characteristics shown on the unit or published in specifications, advertising or other literature controlled by the manufacturer, at stated Rating Conditions.

3.12.1 *Application Rating.* A rating based on tests performed at application Rating Conditions (other than Standard Rating Conditions).

3.12.2 *Standard Rating.* A rating based on tests performed at Standard Rating Conditions as defined in ARI Standard 1060.

3.13 *Purge.* The removal of exhaust air that may be carried to the supply (intake) airstream by a Rotary Heat Exchanger. It is accomplished by shunting a portion of the supply air back into the exhaust air.

3.14 *Rating Conditions.* Any set of operating conditions under which a single level of performance results and which cause only that level of performance to occur.

3.14.1 *Standard Rating Conditions.* Rating conditions used as the basis for comparison for performance characteristics.

3.15 *Should.* “Should” is used to indicate provisions which are not mandatory but which are desirable as good practice.

3.16 *Supply Airflow.* The outdoor airflow, also referred to as rated airflow.

3.16.1 *Entering Supply Airflow.* The supply airstream before passing through the heat exchanger, also referred to as outdoor air, and defined in ASHRAE Standard 84 as Station 1.

3.16.2 *Leaving Supply Airflow.* The supply airstream after passing through the heat exchanger, also referred to as supply air (to building), and defined in ASHRAE Standard 84 as Station 2.

3.16.3 *Net Supply Airflow.* That portion of the Leaving Supply Airflow that originated as Entering Supply Airflow. The Net Supply Airflow is determined by subtracting air transferred from the exhaust side of the heat exchanger from the gross airflow measured at the Supply Airflow leaving the heat exchanger and is given by the equation:

$$\text{Net Supply Airflow} = \text{Leaving Supply Airflow} \cdot (1 - \text{EATR})$$

3.17 *Tempered Outside Air.* The leaving supply air from the Air-to-Air Heat Exchanger. The Tempered Outside Air conditions typically replace the “outdoor air conditions” in most design load software programs. This is also referred to as entering air.

3.18 *Total Building Load.* The total calculated space conditioning requirements for a building.

3.19 *Total Zone Load.* The total calculated space conditioning requirements for a specific zone, including its interior heat sources and sinks (people, lights, computers, refrigerated cases, etc.), infiltration, outdoor air ventilation load, solar load, and orientation. The Total Zone Load may be calculated for both cooling and heating design conditions.

3.20 *Zone.* An area of a building that is conditioned by an individual air-conditioning system.

Section 4. Air-to- Air Energy Recovery Ventilation Equipment (AAERVE) Classifications

4.1 *Integrated Systems.*

4.1.1 *Air-Handling System.* An integrated air-handling system has the air-handling unit manufactured with the Air-to-Air Heat Exchanger installed as part of the air-handler. This system does not require a separate duct system because it utilizes the air-conditioning unit’s duct system.

4.1.2 *Packaged System.* An integrated packaged system has the air-conditioning unit manufactured with the Air-to-Air Heat Exchanger component installed as part of the unit. This system does not require a separate duct system because it utilizes the air-conditioning unit’s duct system.

4.2 *Stand Alone System.* A stand alone system utilizes the AAERVE in a configuration that has a totally separate duct system (for the supply air and the exhaust air) from any other air-conditioning system in the building.

4.3 *Stand Alone Coupled System.* A stand alone coupled system utilizes the AAERVE in a configuration that has part or all of the AAERVE air (supply or exhaust) ducted to the duct system of an air-conditioning system.

4.4 *Unitized System.* A unitized system has an AAERVE accessory attached directly to the air-conditioning equipment, typically in the field. This system does not require a separate duct system.

Section 5. Frost and Condensation

5.1 *Frost Control.* In cold climates, means of avoiding frost or removing frost from the Air-to-Air Heat Exchanger may be required.

5.1.1 *Exhaust Only.* When frost is indicated on the component, the intake blower is de-energized for a period of time to allow exhaust air to warm the component, melt frost, and drain or evaporate condensate. Alternately, exhaust-only operation is determined based on outside air temperature to avoid frosting.

5.1.2 *Preheat.*

5.1.2.1 *Outdoor Air Preheat.* Heat is provided in the outdoor air intake to heat the air to a temperature above the Air-to-Air Heat Exchanger frost threshold before it enters the component.

5.1.2.2 *Return Air Preheat.* Heat is provided in the Entering Exhaust Airflow before it enters the Air-to-Air Heat Exchanger to prevent frost from forming.

5.1.3 *Re-circulation.*

5.1.3.1 *Return Air Re-circulation.* Entering Exhaust Airflow is substituted, in whole or in part, for outside air passing through the Air-to-Air Heat Exchanger for defrost purposes.

5.1.3.2 *Exhaust Air Re-circulation.* Leaving Exhaust Airflow from the Air-to-Air Heat Exchanger is substituted, in whole or in part, for outside air passing through the Air-to-Air Heat Exchanger for defrost purposes.

5.1.4 *Modulated Effectiveness.*

5.1.4.1 *Bypass.* A portion of the outdoor air is bypassed around the heat exchanger until the frost threshold is avoided.

5.1.4.2 *Variable speed.* For Rotary Heat Exchangers the speed of rotation is slowed, reducing Effectiveness, until the frost threshold is avoided.

5.1.4.3 *Tilt Mechanism.* For Heat Pipe Heat Exchangers relying solely or in part on gravity for liquid refrigerant transport. The tilt angle is changed, reducing Effectiveness until the frosting threshold is avoided; or the tilt angle is reversed, effectively stopping heat transfer.

5.1.4.4 *Cold Corner Damper or Traversing Defrost.* For Plate Heat Exchangers, outdoor air is prevented from entering a portion of the Air-to-Air Heat Exchanger to enable the exhaust air energy to defrost that section of the component.

5.2 *Condensation Removal.* Means of removing condensate may be required. If so, observe applicable codes for piping and trapping of condensate drain(s).

Section 6. System Balancing

6.1 *Balancing Considerations.*

6.1.1 *Energy Impacts.* Equal (balanced) Supply and Exhaust Airflows provide the maximum energy recovery for a given AAERVE. The system should be balanced as closely as possible as long as other conditions, such as requirements for building pressurization, are met.

6.1.2 *Conditions Impact.* Unequal airflows will influence the conditions of the supply air. Example: Reducing the Supply Airflow as compared to the exhaust will improve the supply air psychrometric conditions, but reduce the energy recovered from the exhaust air. On the other hand, reducing the Exhaust Airflow as compared to the supply will degrade the supply air psychrometric conditions. Again, energy recovered will be reduced.

6.1.3 *Variable Air Flow.* On systems that vary total system airflow and/or outdoor air (demand control ventilation, variable air volume, etc.) provisions should be made to control both Supply and Exhaust Airflows in concert. In no case should the airflows be lower than needed to provide the required outdoor air ventilation rate per ASHRAE standards or local codes.

6.1.4 *Building or Zone Pressurization.* Requirements for building or zone pressurization should be considered when designing and/or balancing the system.

6.2 *Balancing Methods.* Provisions should be made for adjusting the airflows to required rates. The methods listed below can be used independently or in combination.

6.2.1 *Dampers.* Dampers may be used to balance airflows to the space to insure proper air distribution to individual zones or connected air-handling equipment. Dampers may also be used to balance AAERVE Supply and Exhaust Airflows.

6.2.2 *Blower Settings.* Methods such as multiple speed motors, adjustments in blower sheaves, etc., may be used to adjust airflows.

6.2.3 *Variable Speed.* Variable frequency drives, electronically commutated motors, and similar variable speed technologies may be used to adjust airflows.

6.2.4 *Unitized.* Operation of the main unitary blower can impact the AAERVE Supply and Exhaust Airflows. Methods should be provided to balance these flows and unitary airflow.

6.2.5 *Integrated.* Operation of the main unitary blower can impact the AAERVE Supply and Exhaust Airflows. Methods should be included to balance these flows.

6.2.6 *Measurement of Flows.* Methods should be provided to measure Supply and Exhaust Airflows for the purpose of balancing. Methods can include static pressure across the component, conventional velocity methods in the duct, or other airflow measuring devices.

6.2.7 *Outdoor Air Correction Factor (OACF).* Consider the impact of OACF to ensure that the correct amount of outside air is introduced to meet the ventilation requirements for the building. Example: If the outdoor air is being measured at the outside air inlet and the $OACF = 1.1$, the measured air volume should be 110% of the required (ventilation design) Supply Airflow. This will ensure that the specified level of outdoor air is being introduced into the building (even with the OACF impact from the Air-to-Air Heat Exchanger).

6.3 *Equal and Unequal Air Flows.* The amount of outside air and exhaust air required may be the result of the building design. Many facilities have exhaust air removed from a variety of sources, other than the AAERVE. In order to maintain a proper air balance in the building, this may result in the need to exhaust less air than the outdoor air requirement. In this case, Effectiveness will be increased by definition (because the percentage of energy extracted from the reduced Exhaust Airflow is increased), however, the conditions of the supply air will be less favorable and the Effectiveness of the building system will be reduced (due to induced exfiltration without benefit of energy recovery). If the exhaust air is greater than the outdoor air intake, Effectiveness would again be increased by definition; supply air conditions would improve, but again, building system Effectiveness would be reduced (in this case due to induced infiltration without benefit of energy recovery).

Section 7. Economizer Operation

7.1 Economizer Operation. Some applications and some codes may require that Economizer operation be provided in conjunction with AAERVE. Note: Full Economizer requires up to 100% of the air-conditioning system airflow.

7.1.1 Bypass Economizer.

7.1.1.1 Unitized and Integrated Systems. Outdoor air is brought into the conditioned space without crossing the component, thus not recovering energy. This can be accomplished by utilizing dampers, bypass duct and dampers, or by moving the Air-to-Air Heat Exchanger out of the outdoor airstream.

7.1.1.2 Coupled Systems. A system is added to introduce outdoor air into the conditioned space without crossing the Air-to-Air Heat Exchanger which utilizes the Economizer on the air-conditioning unit.

7.1.2 Wheel Economizer. A System that introduces outdoor air into the conditioned space while crossing a Rotary Heat Exchanger without energy recovery. The component is stopped during the economizer period when energy recovery is not desired. All of the outdoor air crosses the component, thus limiting the outdoor air amount to the component's airflow capacity at the application static pressure. Typically, full 100% outside air economizer function can be provided with this method only for 100% outdoor air systems.

7.2 Modulation. All the above methods can be controlled to provide partial or modulated economizer function.

7.3 Exhaust Air Relief. Barometric relief or power exhaust is often provided in conjunction with Economizers. The exhaust fan in the AAERVE may be able to provide or assist with this function. This should be considered in the design.

Section 8. Design Considerations and Air-Conditioning Equipment Selection

8.1 General. The following should be considered when selecting and applying an AAERVE:

- a. Building design
- b. Building codes
- c. Building locale (climate consideration)
- d. Building operation
- e. Building air-conditioning system
- f. Building outdoor air requirements
- g. Building outdoor air intake location
- h. Building inside air conditions
- i. Building structure limitations

8.1.1 Building Design. The type of building will determine the type of AAERVE required for the application. The design may require that the AAERVE be utilized in a mechanical room application, a rooftop application, a through-the-wall application, or a combination.

8.1.2 Building Codes. The authority having jurisdiction will require that the system adhere to all applicable codes.

8.1.3 Climate. The location of the building may determine the type of AAERVE required. The temperature and humidity conditions should be considered when determining the system to be used.

8.1.4 Building Operation. Controls should be provided to operate the system as required.

8.1.5 Building Air-Conditioning System. The air-conditioning system type utilized in the building structure will influence which AAERVE system will be easiest to install and maintain.

8.1.6 Building Outdoor Air Requirements. The required amount of outside air will affect the size and design of the AAERVE.

8.1.7 Building Outdoor Air Intake Location. The location of the outdoor air intake should be considered. Never use outdoor air from an area that generates contaminated air. Examples of this are (1) areas where idling cars, trucks, or buses are abundant, (2) a processing facility that produces odors, and (3) restaurants’ kitchen (grease) exhaust areas.

8.1.8 Building Inside Air Conditions. The quality of the air inside the building may be important to the selection and design of the AAERVE. If the quality of the exhaust air is objectionable, the EATR should be evaluated. The EATR may be minimized through technology selection, mechanical purge, and/or pressure management. Separate spaces that must remain absolutely separated due to concerns for smoking odor transfer, for example, should be treated with different systems. When exhaust air presents a safety hazard and is not acceptable for recirculation in any amount, the use of AAERVE may not be advisable. Table 1 provides a summary of classes of air as they are treated in ANSI/ASHRAE Standard 62.1.

Table 1: Classes of Air and Energy Recovery Ventilation Applications

Classification of Exhaust Air and Dilution Limits (Refer to ANSI/ASHRAE 62.1 Addendum y)	Recommendations
Class 1 Air - General Space Conditioning Re-circulation permitted.	Use EATR and OACF to calculate adjusted intake rates and insure that proper outside air ventilation is provided.
Class 2 Air - Toilet Exhaust, etc. Supply air is acceptable when no more than 10% is class 2 air.	Minimize EATR to reduce re-circulation of exhaust air. Most devices will require no special measures to achieve this level of dilution. System design, including multiple exhaust points from a variety of spaces can increase dilution performance.
Class 3 Air - Education Lab, Dry Cleaning, etc. Supply air is acceptable when no more than 5% is class 3 air.	Minimize EATR to reduce re-circulation of exhaust air. System design, including separate exhaust air duct systems for class 3 exhaust, multiple exhaust points including class 1 and 2 air, purge, etc., will influence dilution performance.
Class 4 Air – Biohazard Facility, etc. Re-circulation prohibited.	AAERVE may not be an acceptable technology. Only specific designs with zero EATR and not susceptible to failure should be used in this application.

8.1.8.1 Fouling. Spaces that generate dust, powder, grease, wax, etc. could require special treatment of the exhaust air or may not be candidates for AAERVE. Verify with the AAERVE manufacturer.

8.1.8.2 Humidity Control. AAERVE in combination with the air-conditioning system may provide adequate humidity control to meet ASHRAE Standard 62.1 requirements. In applications where humidity must be closely controlled (within 5%) additional dehumidification equipment may be required.

8.1.8.3 Smoking Areas. If smoking is allowed inside the space, additional amounts of outdoor air may be required. Consult local codes for the minimum amount required. Consult the AAERVE manufacturer for appropriate product application.

8.1.9 Building Structure Installation Considerations. Listed below are examples of limitations created due to the structure of a building. This is just a partial list.

- 8.1.9.1** The amount of room required for ductwork
- 8.1.9.2** The size of the mechanical room as it relates to the size of the equipment
- 8.1.9.3** The location of exhaust and flue gas and plumbing vents on a roof
- 8.1.9.4** Maintenance access to the AAERVE
- 8.1.9.5** Electrical requirements

8.2 Selection of Cooling Design Conditions. Outside air can be a significant source of humidity. ASHRAE Handbook - Fundamentals provides three different sets of cooling design conditions. The dry-bulb/mean wet-bulb data prioritizes sensible

load; the wet-bulb/mean dry-bulb data prioritizes latent load; the dewpoint/mean dry-bulb data prioritizes humidity ratio. The choice of design conditions may impact the efficiency of the system and its ability to control indoor humidity.

8.3 *Tonnage Reduction Method.* The air-conditioning equipment size can be determined by reducing the Total Building Load by the tonnage saved due to the AAERVE.

8.3.1 *Total Air-Conditioning Requirement.* Determine the total air-conditioning required for the Total Building Load including the amount required for the ventilation.

8.3.2 *AAERVE Tonnage Savings.* Determine the amount of air-conditioning tonnage that the AAERVE is saving from the manufacturer's data. Reduce the total air-conditioning requirement by the savings amount to determine the net air-conditioning requirement.

8.4 *Entering Outdoor Air Method* Determine the total air conditioning load by replacing the entering outdoor air conditions in load programs with the entering tempered outside air conditions.

Section 9. AAERVE Sizing

9.1 *General.* The following information is required to determine the AAERVE needs.

- a. Outside air required per zone
- b. Exhaust air required per zone.
- c. Summer design conditions
- d. Winter design conditions
- e. Desired sensible Effectiveness
- f. Desired latent Effectiveness
- g. External static pressure requirements (supply and exhaust) as applicable

Section 10. Specification Practices for AAERVE

10.1 *AAERVE Requirements.*

10.1.1 *Energy Recovery Performance and Effectiveness.* Specify either sensible or enthalpy type recovery device with the desired Effectiveness. Enthalpy devices should be used where it is advantageous to conserve or reject humidity. Sensible devices provide an advantage when it is desirable to allow dehumidification with outside air (winter ventilation of pools or other spaces with excessive humidity, for example).

10.1.2 *Other Performance Requirements.* Specify additional performance ratings that may be applicable to the design such as pressure drop, EATR, and OACF.

10.1.3 *Recovery Type.* Specify either Heat Pipe Heat Exchanger, Plate Heat Exchanger, or Rotary Heat Exchanger that corresponds to the recovery performance and Effectiveness selected.

10.1.4 *Installation Type.* Specify installation and application for AAERVE that is applicable for the recovery type selected. Example: Rooftop, indoor, coupled, unitized, etc.

10.2 *AAERVE Design Information.*

10.2.1 *Balancing Method.* Specify the method to be used for balancing the airflow of exhaust and supply (intake) air. Specify the airflows and locations for airflow measurement, including the impact of OACF and EATR on those flows.

10.2.1.1 Integrated systems should have an internal means of controlling exhaust air without being overwhelmed by the air-handler supply blower.

10.2.1.2 Stand alone systems should have balancing dampers installed for each Zone to control the amount of outdoor air for each Zone.

- 10.2.1.3** Stand alone-coupled systems that are connected to the air-conditioning duct of multiple air-conditioning systems should have balancing dampers installed at each location where the AAERVE is attached to each individual air-conditioning duct.
- 10.2.1.4** Unitized Systems should provide an internal balancing damper to control exhaust air without being overwhelmed by the air-conditioning unit supply blower.
- 10.2.2** *Design Conditions.* Specify the summer and winter design conditions. Include both dry-bulb and wet-bulb temperatures.
- 10.2.3** *Economizer Requirement.* Specify economizer type to be utilized (if any) for the AAERVE.
- 10.2.4** *Exhaust Air Requirement.* Specify the amount of exhaust air to be removed from the conditioned space.
- 10.2.5** *External Static Pressure.* On stand alone and stand alone-coupled systems the amount of external duct static that the AAERVE must overcome to provide the outdoor air and exhaust air required should be specified. On integrated and unitized systems, the air-conditioning system should be sized to overcome the external duct static.
- 10.2.6** *Frost Protection.* Specify type of frost protection required per the Air-to-Air Heat Exchanger manufacturer's guidelines.
- 10.2.7** *Maintenance Requirement.* Specify the access required to properly maintain the Air-to-Air Heat Exchanger. This should provide a method of accessing all motors, controls, and the component.
- 10.2.7.1** *Component Cleaning.* The Air-to-Air Heat Exchanger is located in both supply and exhaust airstreams. As such, this component will require cleaning on a periodic basis. Access to the component and a method of cleaning should be specified to insure longevity of the component.
- 10.2.8** *Filtration.* Specify type of filtration required per the Air-to-Air Heat Exchanger manufacturer's guidelines.
- 10.2.9** *Mating Unit.* Specify the air-handler or the stand alone-coupled or unitized system to which the AAERVE is mated.
- 10.2.10** *Outdoor Air Requirement.* Specify the amount of outdoor air to be brought into the conditioned space. On integrated, stand alone-coupled, or unitized systems the outdoor air should not exceed the air-conditioning system's standard airflow capacities.
- 10.2.11** *Airflow Verification.* Specify the procedure for verifying the amount of outdoor air and exhaust air. This information should be part of the commissioning of the building.
- 10.2.12** *Electrical.* Specify the voltage, phase, and current requirements for the AAERVE equipment.
- 10.2.13** *Ducts.* Specify the type and size of ducts to be used, along with the method of insulating and sealing the ducts. When tempered outside air or exhaust air leaving the AAERVE is ducted through a conditioned space, ducts should be properly insulated and sealed to prevent energy loss and or formation of condensate or frost. Similar cautions apply to ducts carrying conditioned air and located outside of the building envelope.
- 10.2.14** *Agency Approvals.* Specify the agency approvals required for the Air-to-Air Heat Exchanger and AAERVE. This should include the ARI Standard 1060 certification seal.

APPENDIX A. REFERENCES – NORMATIVE

None.

APPENDIX B. REFERENCES – INFORMATIVE

B1 Listed here are standards, handbooks and other publications which may provide useful information and background, but are not considered essential. References in this appendix are not considered part of the guideline.

B1.1 ANSI/ASHRAE Standard 62.1-2004, *Ventilation for Acceptable Indoor Air Quality*, 2004, American Society of Heating, Refrigerating and Air-Conditioning Engineers, Inc., 1791 Tullie Circle N.E., Atlanta, GA 30329, U.S.A.

B1.2 ARI Guideline V-2003, *Calculating the Efficiency of Energy Recovery Ventilation and its Effect on Efficiency and Sizing of Building HVAC Systems*, 2003, Air-Conditioning and Refrigeration Institute, 4100 North Fairfax Drive, Suite 200, Arlington, VA 22203, U.S.A.

B1.3 ARI Standard 1060-2005, *Rating Air-to-Air Energy Recovery Ventilation Equipment*, 2005, Air-Conditioning and Refrigeration Institute, 4100 North Fairfax Drive, Suite 200, Arlington, VA 22203, U.S.A.

B1.4 ASHRAE Handbook - Fundamentals, 2005, American Society of Heating, Refrigerating and Air-Conditioning Engineers, Inc., 1791 Tullie Circle N.E., Atlanta, GA 30329, U.S.A.

B1.5 ASHRAE Handbook - Systems and Equipment, 2004, American Society of Heating, Refrigerating and Air-Conditioning Engineers, Inc., 1791 Tullie Circle N.E., Atlanta, GA 30329, U.S.A.

B1.6 ASHRAE Standard 84-1991, *Method of Testing Air-to-Air Heat Exchangers*, 1991, American Society of Heating, Refrigerating and Air-Conditioning Engineers, Inc., 1791 Tullie Circle N.E., Atlanta, GA 30329, U.S.A.

B1.7 ASHRAE *Terminology of Heating, Ventilation, Air Conditioning and Refrigeration* 1991 Second Edition, American Society of Heating, Refrigerating and Air-Conditioning Engineers, Inc., 1791 Tullie Circle N.E., Atlanta, GA 30329, U.S.A.

B1.8 International Mechanical Code, 2003, International Code Council, 5203 Leesburg Pike, Suite 600, Falls Church, VA 22041, U.S.A.

Appendix C. Example Specification for Stand Alone System, Rooftop or Indoor– Informative

Stand Alone Energy Recovery Equipment Schedule				
Mark		HRV-1	ERV-2	
Area Served		Class 2	Library	
Manufacturer		ABC Inc.	ABC Inc.	
Model		A-1000	B-2000	
Summer Conditions	Outdoor Air Temperature, Dry-Bulb - °F		89	
	Outdoor Air Temperature, Wet-Bulb - °F		73	
	Indoor Air Temperature, Dry-Bulb - °F		75	
	Indoor Air Temperature, Wet-Bulb - °F		63	
	Effectiveness – Sensible - %	71	75	
	Effectiveness – Latent - %	0	67	
Winter Conditions	Outdoor Air Temperature, Dry-Bulb - °F		1	
	Outdoor Air Temperature, Wet-Bulb - °F		0	
	Indoor Air Temperature, Dry-Bulb - °F		72	
	Indoor Air Temperature, Wet-Bulb - °F		54	
	Effectiveness – Sensible - %	71	75	
	Effectiveness –Latent - %	0	67	
Supply	Net Outdoor Airflow – cfm		1000	
	Gross Outdoor Airflow - cfm		1000	
	Supply Conditions, Dry-Bulb / Wet-Bulb - °F		79 / 70	
	Winter Conditions, Dry-Bulb / Wet-Bulb - °F		51 / 35	
	Blower Motor	Horsepower		1
		Volts		460
		Phase / Hertz		3 / 60
		External Static Pressure in H ₂ O		0.25
Exhaust	Net Exhaust Airflow – cfm		1000	
	Gross Exhaust Airflow - cfm		1000	
	Blower Motor	Horsepower		1
		Volts		460
		Phase / Hertz		3 / 60
		External Static Pressure H ₂ O		0.2
	Min.Circuit Ampacity, A		4.8	5.7
	Max. fuse Size, A		6	10
Remarks (refer to notes regarding defrost, economizers, balancing dampers, etc.)				

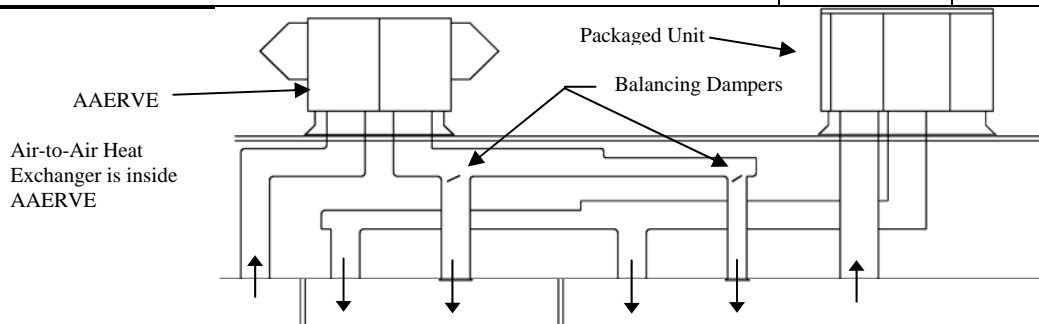

Figure C1. Typical Stand Alone System - Rooftop

Appendix D. Example Specification for Stand Alone - Coupled System, Rooftop or Indoor – Informative

Stand Alone - Coupled Energy Recovery Equipment Schedule					
Mark		HRV-1	ERV-2		
Coupled with		AHU-1	RTU-1		
Manufacturer		ABC Inc.	ABC Inc.		
Model		A-1000	B-2000		
Summer Conditions	Outdoor Air Temperature, Dry-Bulb - °F		89		
	Outdoor Air Temperature, Wet-Bulb - °F		73		
	Indoor Air Temperature, Dry-Bulb - °F		75		
	Indoor Air Temperature, Wet-Bulb - °F		63		
	Effectiveness – Sensible - %	71	75		
	Effectiveness – Latent - %	0	67		
Winter Conditions	Outdoor Air Temperature, Dry-Bulb - °F		1		
	Outdoor Air Temperature, Wet-Bulb - °F		0		
	Indoor Air Temperature, Dry-Bulb - °F		72		
	Indoor Air Temperature, Wet-Bulb - °F		54		
	Effectiveness – Sensible - %	71	75		
	Effectiveness – Latent - %	0	67		
Supply	Net Outdoor Airflow – cfm		1000	1800	
	Gross Outdoor Airflow - cfm		1000	1870	
	Supply Conditions, Dry-Bulb / Wet-Bulb - °F		79 / 70	79 / 66	
	Winter Conditions, Dry-Bulb / Wet-Bulb - °F		51 / 35	51 / 41	
	Blower Motor	Horsepower		1	1.5
		Volts		460	
		Phase / Hertz		3 / 60	
		External Static Pressure in H ₂ O		0.25	0.3
Exhaust	Net Exhaust Airflow – cfm		1000	1700	
	Gross Exhaust Airflow - cfm		1000	1770	
	Blower Motor	Horsepower		1	1.5
		Volts		460	
		Phase / Hertz		3 / 60	
		External Static Pressure in H ₂ O		0.2	0.25
Min. Circuit Ampacity, A		4.8	5.7		
Max. Fuse Size, A		6	10		
Remarks (refer to notes regarding defrost, economizers, balancing dampers, etc.)					

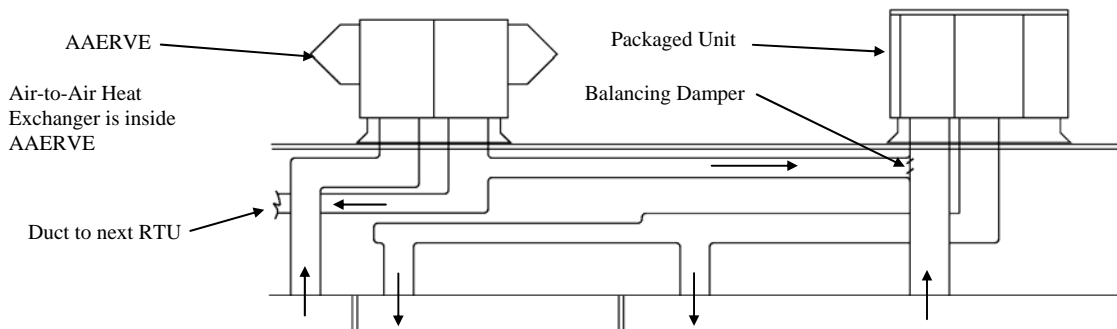

Figure D1. Typical Stand Alone-Coupled System (one of many possibilities)

Appendix E. Example Specification for Unitized System, Rooftop or Indoor – Informative

Unitized Energy Recovery Equipment Schedule				
Mark		HRV-1	ERV-2	
Connected to		AHU-1	RTU-1	
Manufacturer		ABC Inc.	ABC Inc.	
Model		U-1000	U-2000	
Summer Conditions	Outdoor Air Temperature, Dry-Bulb - °F		89	
	Outdoor Air Temperature, Wet-Bulb - °F		73	
	Indoor Air Temperature, Dry-Bulb - °F		75	
	Indoor Air Temperature, Wet-Bulb - °F		63	
	Effectiveness – Sensible - %	71	75	
	Effectiveness – Latent - %	0	67	
Winter Conditions	Outdoor Air Temperature, Dry-Bulb - °F		1	
	Outdoor Air Temperature, Wet-Bulb - °F		0	
	Indoor Air Temperature, Dry-Bulb - °F		72	
	Indoor Air Temperature, Wet-Bulb - °F		54	
	Effectiveness – Sensible - %	71	75	
	Effectiveness – Latent - %	0	67	
Supply	Net Outdoor Airflow – cfm		1000	
	Gross Outdoor Airflow - cfm		1000	
	Supply Conditions, Dry-Bulb / Wet-Bulb - °F		79 / 70	
	Winter Conditions, Dry-Bulb / Wet-Bulb - °F		51 / 35	
	Blower Motor	Horsepower		1
		Volts		460
		Phase / Hertz		3 / 60
		External Static Pressure in H ₂ O		0.25
Exhaust	Net Exhaust Airflow – cfm		1000	
	Gross Exhaust Airflow - cfm		1000	
	Blower Motor	Horsepower		1
		Volts		460
		Phase / Hertz		3 / 60
		External Static Pressure in H ₂ O		0.2
Min. Circuit Ampacity, A		4.8	5.7	
Max. Fuse Size, A		6	10	
Remarks (refer to notes regarding defrost, economizers, balancing dampers, etc.)				

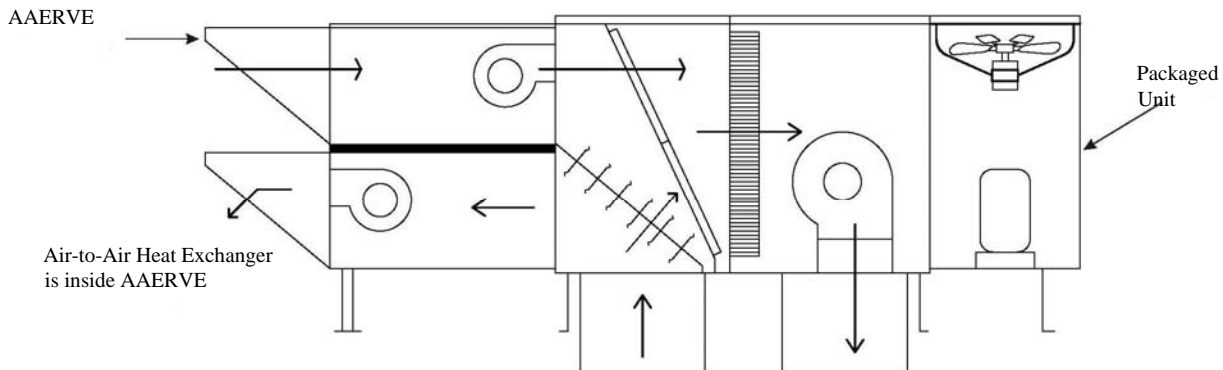

Figure E1. Unitized System

Appendix F. Example Specification for Integrated Energy Recovery System, Rooftop or Indoor – Informative

Integrated Energy Recovery Equipment Schedule					
Mark		HRV-1	ERV-2		
Area Served		Class 2	Library		
Manufacturer		ABC Inc.	ABC Inc.		
Model		AB120-1000	AB240-2000		
Summer Conditions	Outdoor Air Temperature, Dry-Bulb - °F		89		
	Outdoor Air Temperature, Wet-Bulb - °F		73		
	Indoor Air Temperature, Dry-Bulb - °F		75		
	Indoor Air Temperature, Wet-Bulb - °F		63		
	Effectiveness – Sensible - %	71	75		
	Effectiveness – Latent - %	0	67		
Winter Conditions	Outdoor Air Temperature, Dry-Bulb °F		1		
	Outdoor Air Temperature, Wet-Bulb - °F		0		
	Indoor Air Temperature, Dry-Bulb - °F		72		
	Indoor Air Temperature, Wet-Bulb - °F		54		
	Effectiveness – Sensible - %	71	75		
	Effectiveness – Latent - %	0	67		
Supply	Net Outdoor Airflow – cfm		1000	1800	
	Gross Outdoor Airflow - cfm		1000	1870	
	Supply Conditions, Dry-Bulb / Wet-Bulb - °F		79 / 70	79 / 66	
	Winter Conditions, Dry-Bulb / Wet-Bulb - °F		51 / 35	51 / 41	
	Blower Motor	Horsepower		1	1.5
		Volts		460	
		Phase / Hertz		3 / 60	
		External Static Pressure in H ₂ O		0.25	0.3
Exhaust	Net Exhaust Airflow – cfm		1000	1700	
	Gross Exhaust Airflow - cfm		1000	1770	
	Blower Motor	Horsepower		1	1.5
		Volts		460	
		Phase / Hertz		3 / 60	
		External Static Pressure in H ₂ O		0.2	0.25
Min. Circuit Ampacity, A		4.8	5.7		
Max. fuse Size, A		6	10		
Remarks (refer to notes regarding defrost, economizers, balancing dampers, etc.)					

Figure F1. Integrated System

Air-to-Air Heat Exchanger is inside Air-Conditioning Unit

